



# Filmatic

A **Trepko** Group Company

and EHEDG Design



**3A/EHEDG Since 1998**



FILMATIC  
Oct 2024

## FILMATIC PROFILE

- ▣ **Established in 1979**
- ▣ **Currently 160 Employees**
- ▣ **Focus on Liquid Industry (water, dairy, juice, edible oil, CSD, food, household products, industrial, etc)**
- ▣ **Main operations in Sub Sahara Africa**
- ▣ **Significant client base in UK,UAE, Europe and Central America**

# Filmatic Vision

**Leading as a Preferred Partner in  
Packaging & Processing Solutions.**



# Filmatic

- ▣ Purpose: Supply Automated Quality, Cost-effective Packaging Solutions for the Packaging Industry.
- ▣ Direction: Developing New Equipment(products),
  - Improve existing equipment and
  - Supply Quality Qualified Agency manufactured equipment for Turnkey solutions coupled with
  - Outstanding After Sales Support.
  - Africa
  - Trepko







# Filmatic

ROTARY LEVEL  
RR36-FRL54-LS-SN-N6  
RINSER FILLER CAPPER



# ROTARY LEVEL FILLER FRL66-LS-N6





# Filmatic

ROTARY NETT-WEIGH  
FILLER CAPPER  
FRW30-LS-B-N6



## Ultraclean Rinser-Filler-Capper (2004)





# Filmatic

LRR72-T12-1-2-410-B  
ROLLFED LABELLER

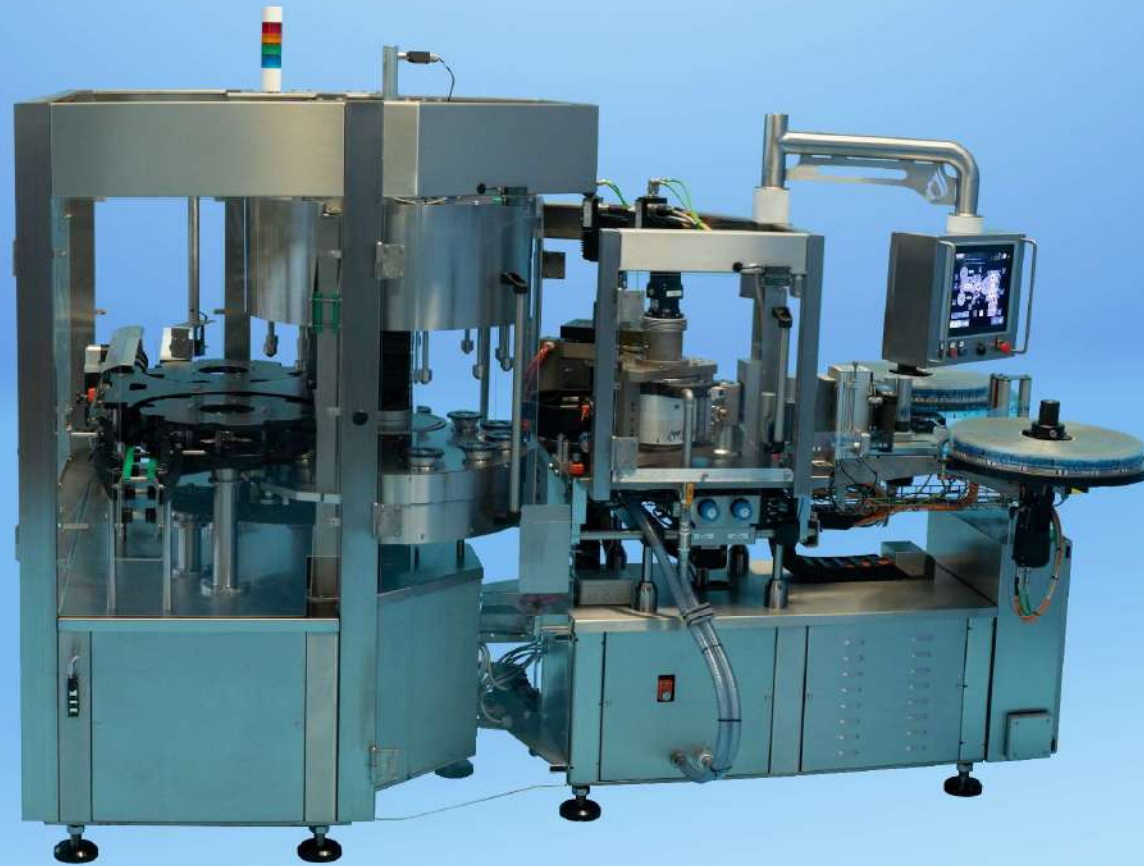

## Rotary Filling Bowl Sizes & Heads

### N4 – Filling Bowl



Heads	Brimfull Volume (ℓ)	Operating Volume (ℓ)
21, 30, 36, 39, 42 & 45	727	160

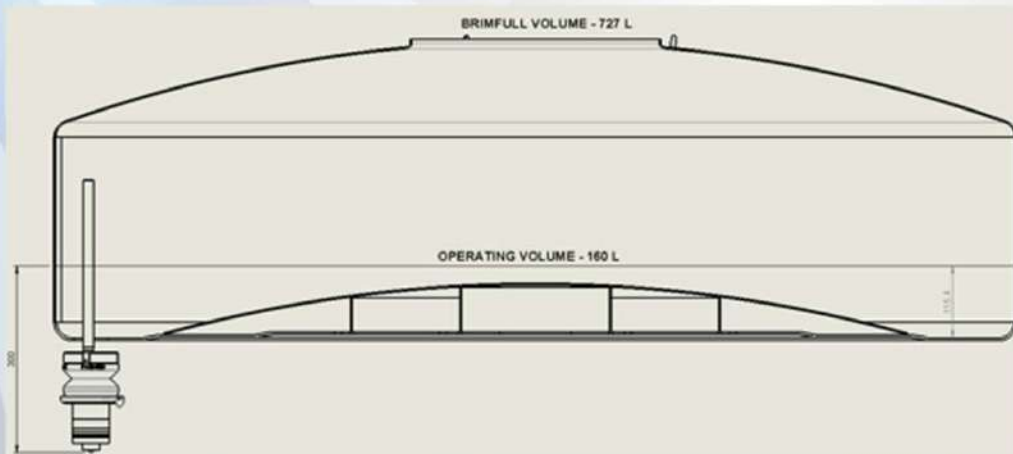

## FIP Filling Tank Sizes & Heads

### FIP Large containers – Filling Bowl



Heads	Brimfull Volume (ℓ)	Operating Volume (ℓ)
3-6	355	176

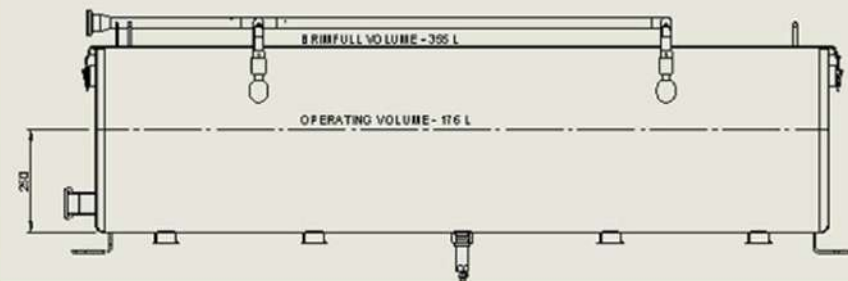

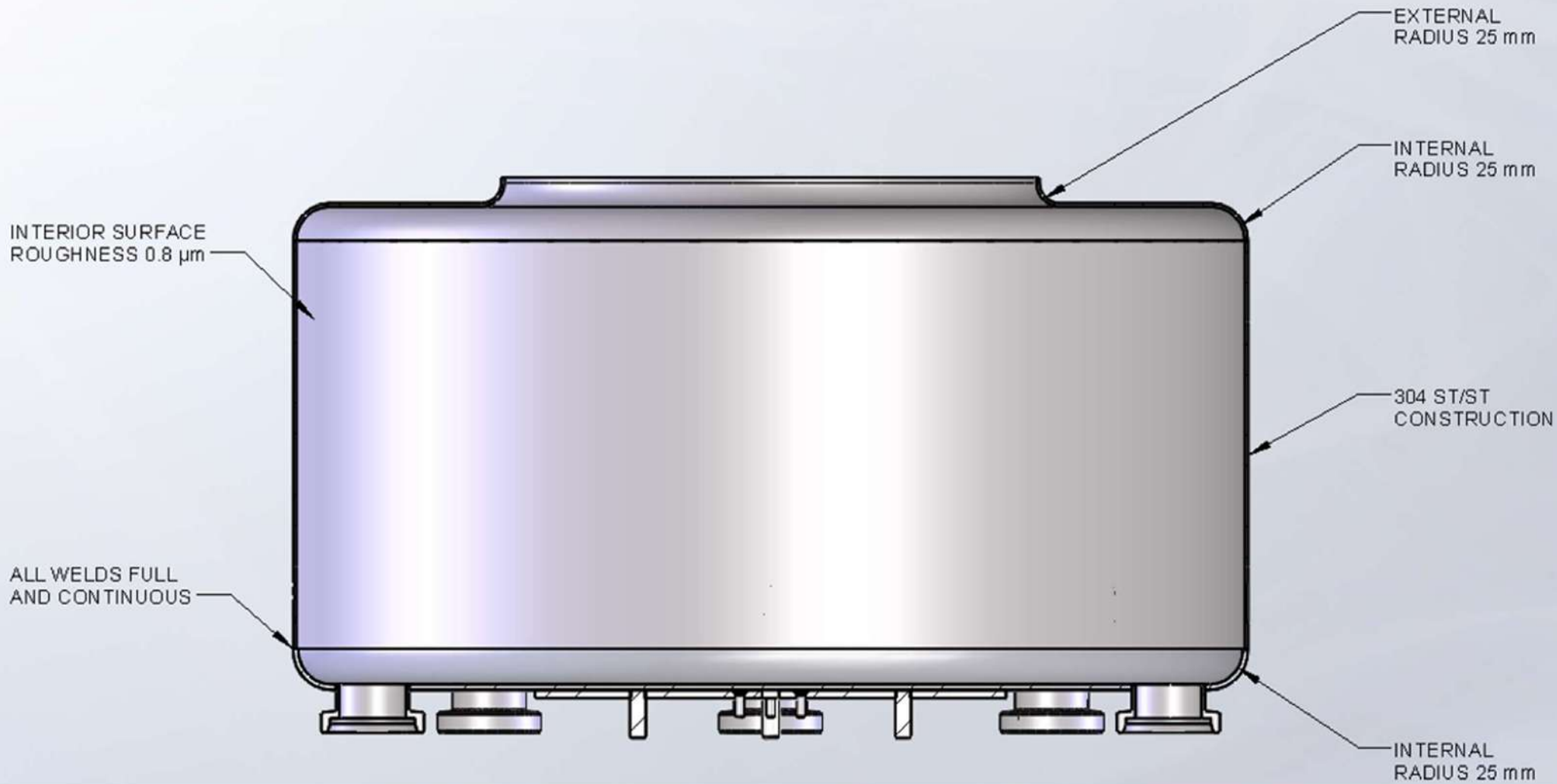

FLOAT SENSOR PICKUP BRACKET

LID VENT EXTERNAL RADIUS 6 mm

LID OUTER EDGE INTERNAL RADIUS 25 mm

ALL WELDS FULL AND CONTINUOUS

316 ST/ST HOLLOW FLOAT

304 ST/ST PRODUCT CONTACT PARTS (UNLESS OTHERWISE SPECIFIED)

316 ST/ST SPRAYBALLS

FOOD-SAFE HDPE LID WEAR RING

INTERIOR SURFACE ROUGHNESS 0.8 µm

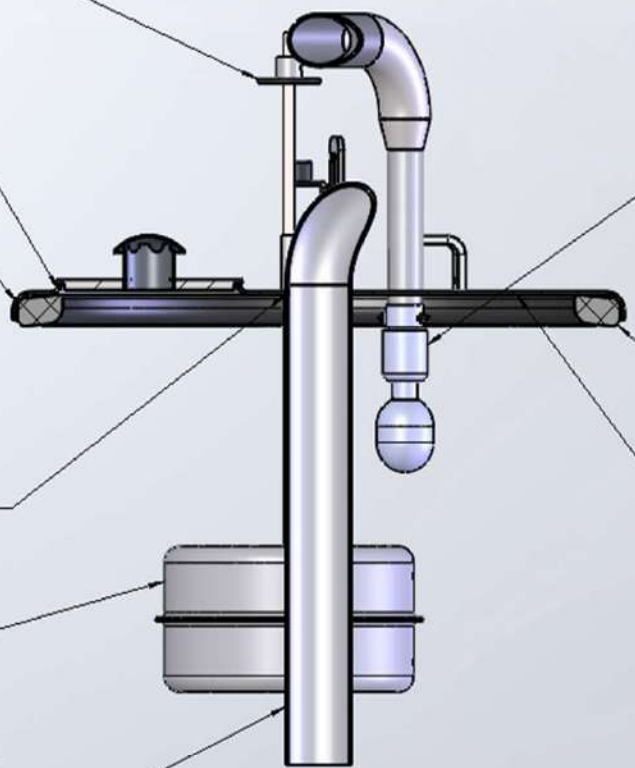

Check that shaft & R-clip is secure in place



Product and CIP Pipes  
Alfagomma 412 LE

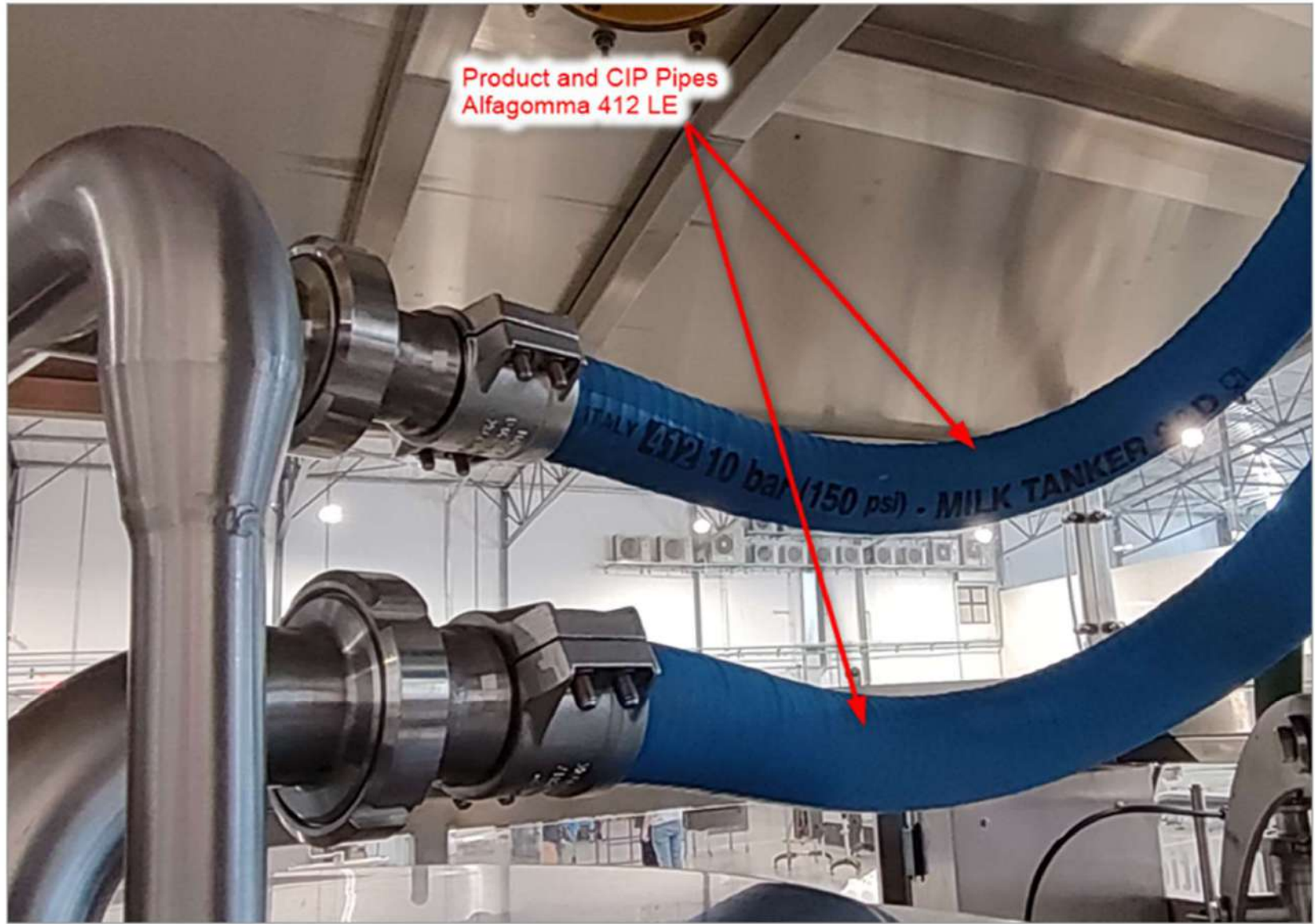

# Auto CIP System



**AUTO CIP SYSTEM**

## Curved Base Design

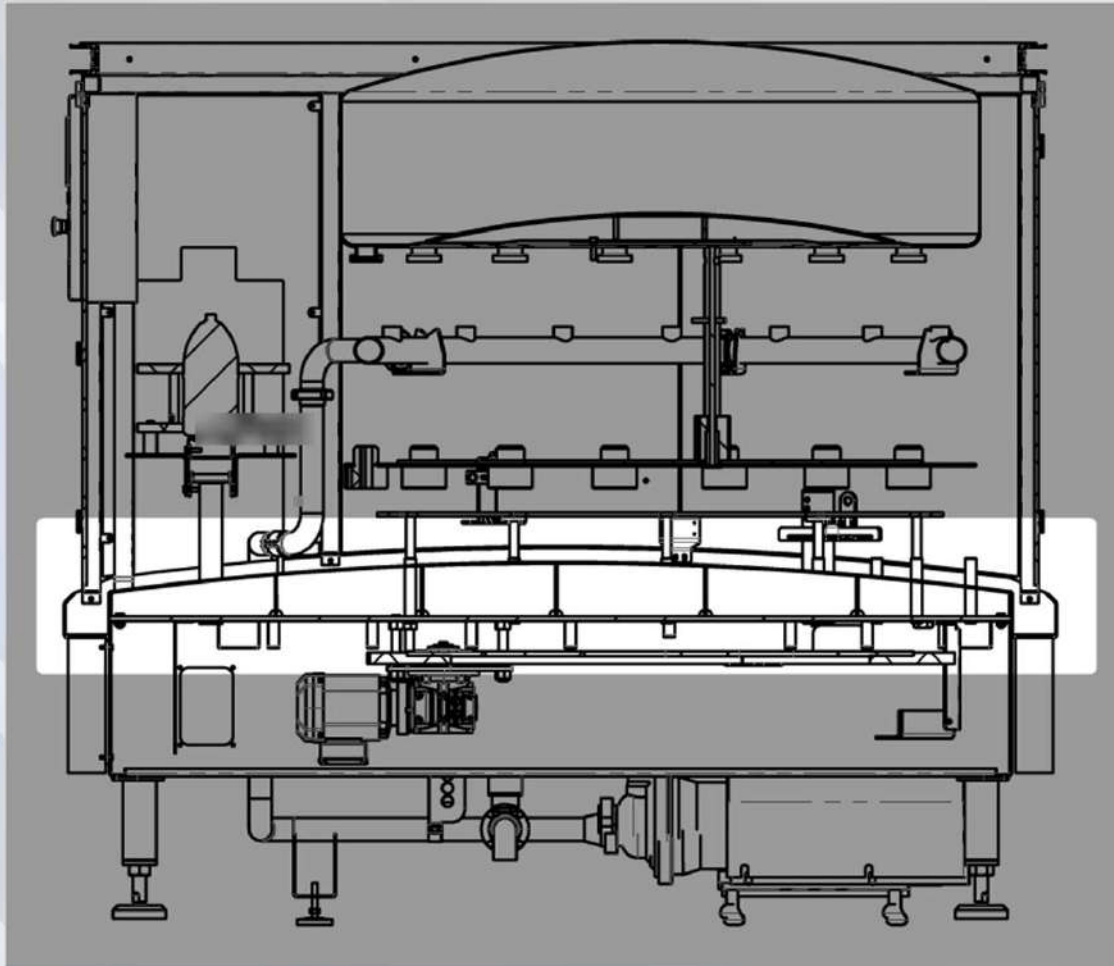

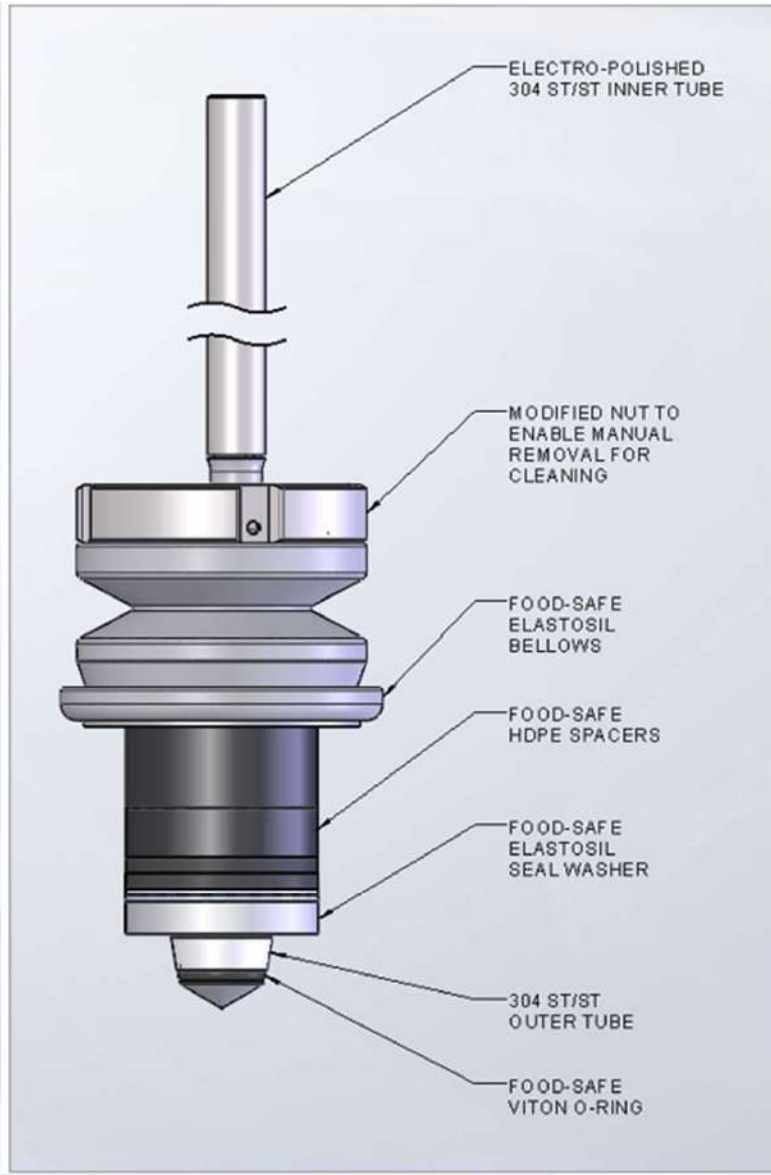



# Filmatic

## Pre Vent vs. Traditional filling valves

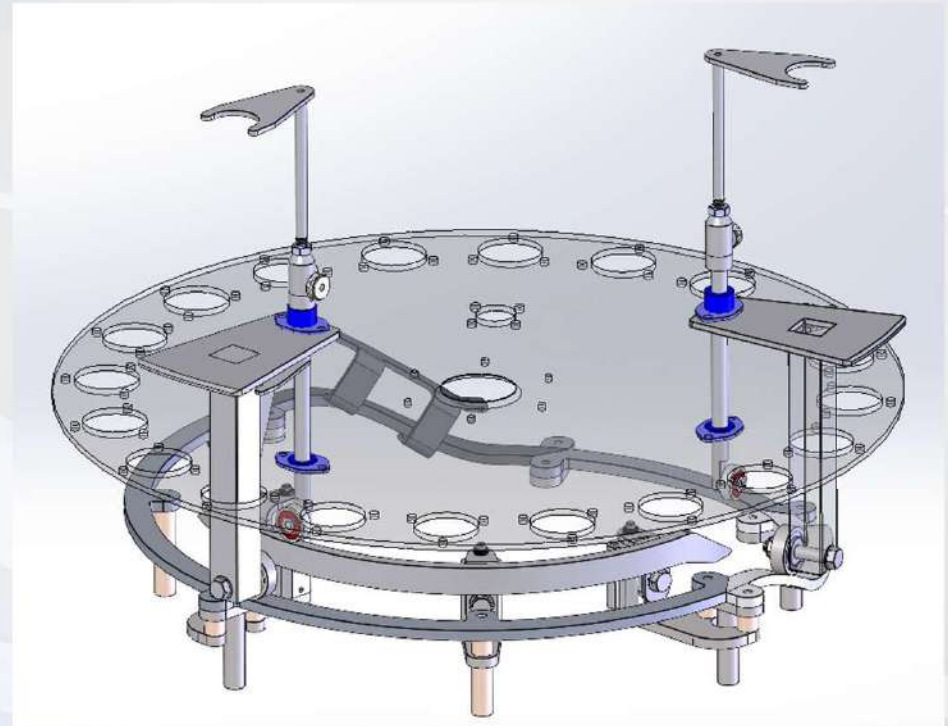

Presented by : John du Plessis  
Date: 07/05/2026





# Nett-Weigh CIP

## Filling cycle

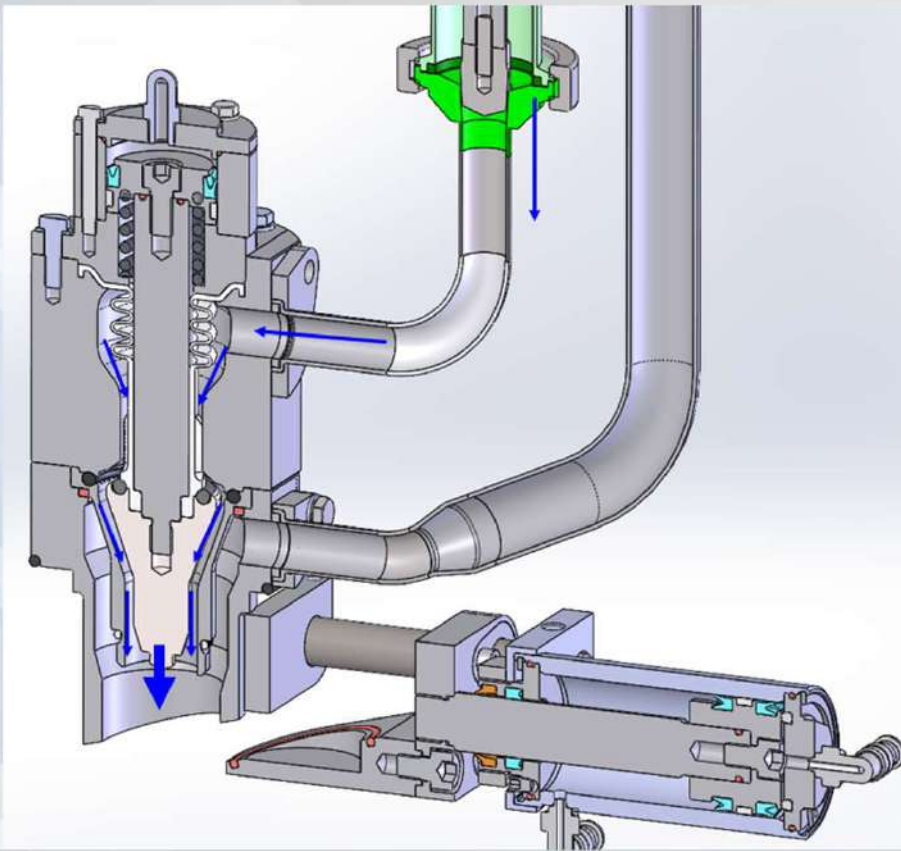

## CIP cycle

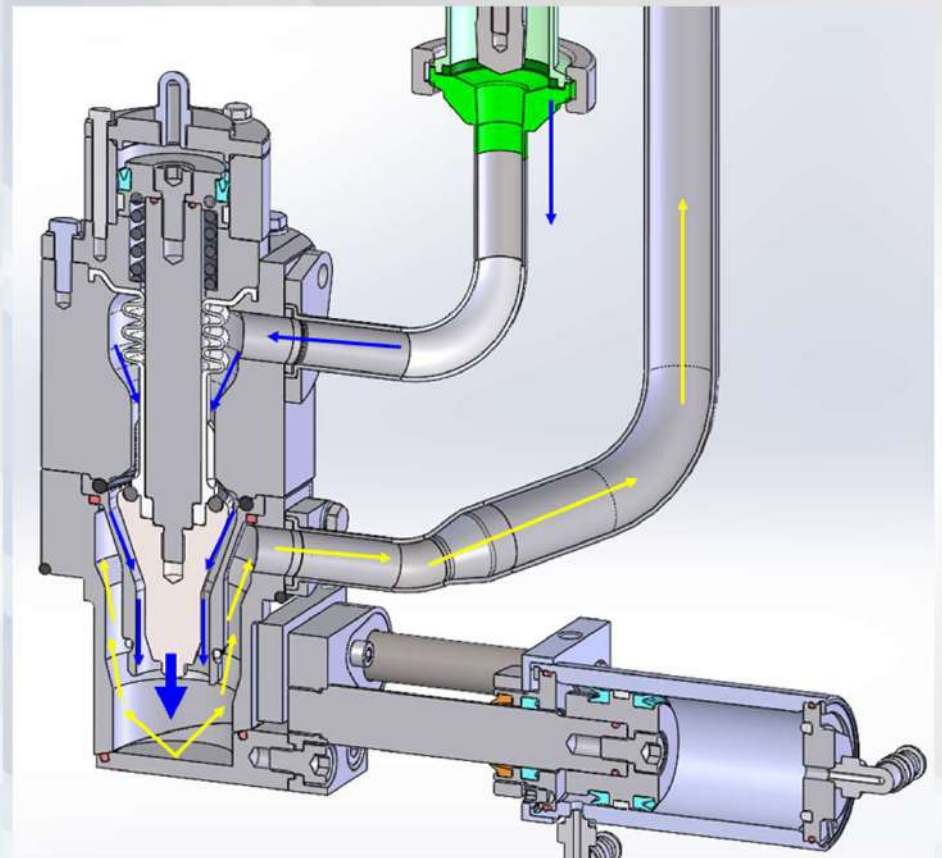



## Tub Filler Improvements

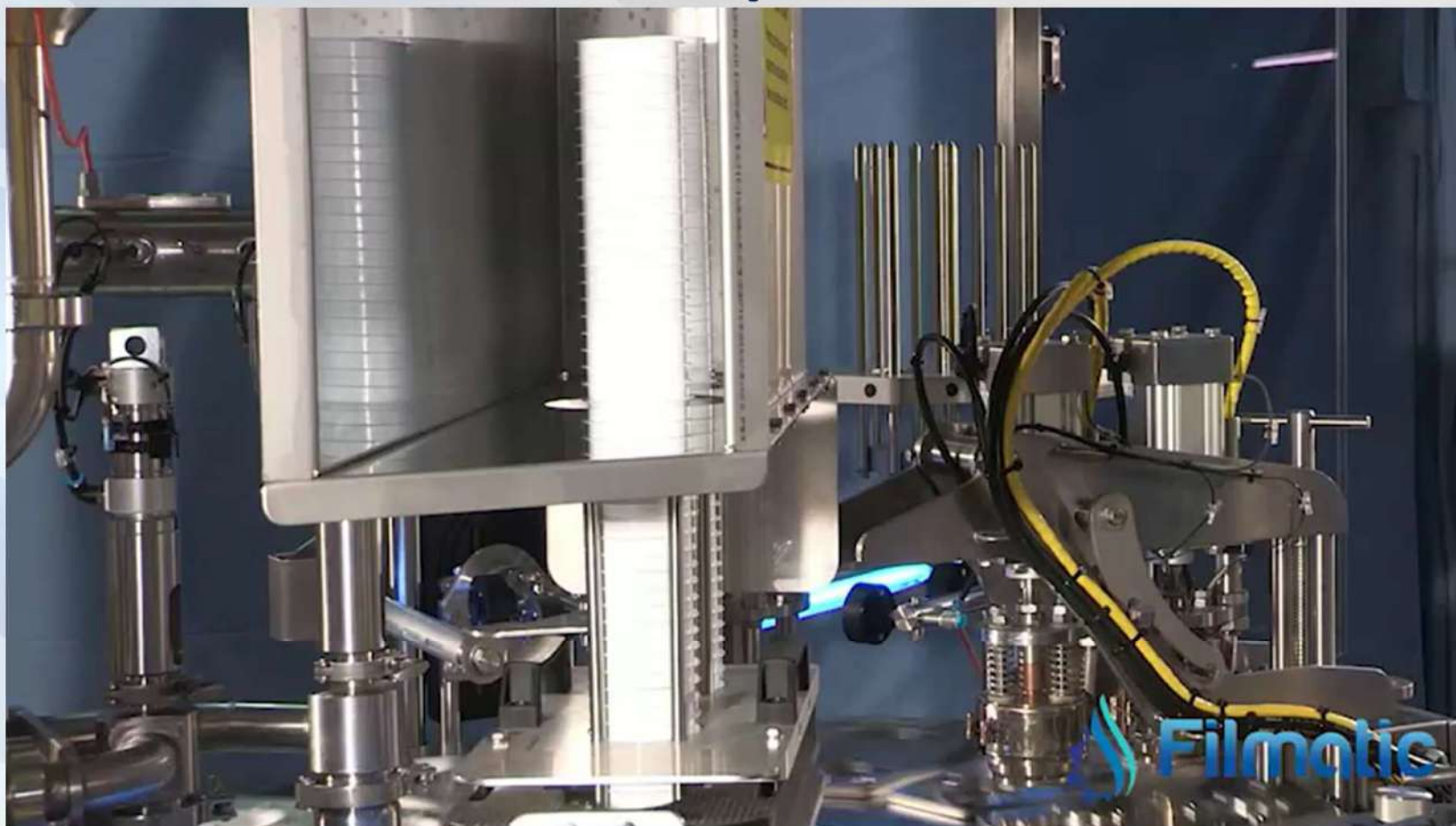

## Product successes

- ▣ Dairy
- ▣ Maheu
- ▣ Sorghum
- ▣ Edible oil
- ▣ Water
- ▣ Fruit Juices
- ▣ STERIMILK
- ▣ Carbonated soft drinks
- ▣ Margarine
- ▣ Yoghurt
- ▣ Peanut Butter
- ▣ Petroleum Jelly
- ▣ Household Products
- ▣ Honey
- ▣ Sauces

## STERILINE (FOIL HEAT SEAL)



## HOTMELT ROLLFED LABELER



## HOTMELT ROLLFED LABELER- DAIRY



## DAIRY- FRESHWAYS (LONDON)



## DAIRY- ESL Application



## ULTRACLEAN FILLING LINE



# Questions

